



Main applications

- Extrusion lines (m/min.)
- Electrical panels
- Speed indicator
- Tachymeter

Main features

- Input from the most common types of sensor
- Protected by a code configurable from keypad
- 4 to 20mA retransmitted output
- Up to 3 relay outputs
- Configurable by a serial link
- Labels to customize measured physical unit

GENERAL

Microprocessor based indicator in 96x48 (1/8 DIN) format manufactured with SMT.

The instruments have a lexan membrane faceplate (guaranteed to IP65) which has 3 keys, a 4 digit display and 3 indicating LED's for the output statuses.

The input signal can be selected from a wide range of sensors:

- voltage free mechanical contact
- Inductive or capacitive proximity switch, encoder or Namur 2 / 3 wires
- 30 to 500Vac, 1mA alternating voltage command

The selection is made using the faceplate keys.

A digital input (24Vdc/4mA) is available for resetting, hold, flash, peak handling or releasing latch.

The instruments can have a maximum of 3 outputs that can be mechanical relays (5A/250V) or logic outputs (0 to 11Vdc).

One output of 4 to 20mA (max. 150Ω) is available for retransmitting the measured input signal.

Finally, a triac can be fitted (as an alternative to the other two relay

outputs) to drive resistive loads up to a maximum of 2,5A at 220V.

The programming of the instrument is made easy by grouping the parameters in function blocks (**CFG** for the alarm hysteresis, **Inp** for the inputs, **Out** for the outputs...) and by a simplified data entry menu.

The configuration can be simplified even further using the PC programming kit made up of a connection cable and a menu guide program that runs under Windows (see technical data cod. WINSTRUM)

A configurable personal software protection code (password protection) can be used to restrict the levels of editing and displaying the configuration parameters.

TECHNICAL DATA

INPUTS

Accuracy 0.1% in modality autorange, ± 1 digit with f.s. fixed

Main input from:

- voltage free mechanical contact configurable in opening/closing, 100Hz filter settable from configuration
- voltage logic command with 0,5 to 30Vdc, 6mA max. range, for inductive or capacitive proximity switch, encoder or NAMUR 2 or 3 wires
- 30 to 500Vac, 1mA max. alternating command

10KHz max. input signal frequency with 50% duty cycle (prescaler set to 1, 2, 4, 10, 20, 40, 100).

Frequency meter with automatic decimal point autoranging for 9,999; 99,99; 999,9; 9999Hz frequency values with 0,1% full scale accuracy.

Freely settable decimal point position, with fixed full scale.

Frequency evaluation modality with settable sampling time, useful for defining a max. interceptions delay time.

Transformation in engineering units is possible through the insert of a multiplier, a divisor and a scale offset (i.e.

for visualisation, RPM interception).

Digital input

Ri = 5,6K Ω (24V, 4mA) isolated to 1500V.

Function is configurable as alarm or memory reset, hold, flash, zero, display of the peak value (max., min. or peak to peak).

OUTPUTS

Relay

NO (NC) contacts rated at 5A/250V at $\cos\phi = 1$.

Logic (only for Out1, Out2)

Type D 11Vdc, Rout = 220 Ω (6V/20mA).

Triac (for Out1, disabled Out2)

24 to 240Vac $\pm 10\%$, max 3A
Snubberless, $I^2t = 128A^2sec$

A maximum of three trip points can be set as absolute, deviation or symmetrical deviation alarms.

The hysteresis of each alarm is individually configurable.

Alarm masking with exclusion on power up, memory and configurable delay and minimum intervention time.

The trip point may be set at any point on the scale.

Analogue retransmission

4 to 20mA on max. 150 Ω load.

POWER SUPPLY

Standard:

100 to 240Vac/dc $\pm 10\%$ max 11,5VA

optional:

11 to 27Vac/dc $\pm 10\%$ max 9VA

50/60Hz, Protected by an internal fuse (not replaceable by the operator).

POWER SUPPLY

TRANSMITTER

5Vdc, max 120mA

12Vdc, max 50mA

24Vdc $\pm 10\%$ unstabilised, max 50mA

AMBIENT CONDITIONS

Working temperature range: 0 to 50°C

Storage temperature range: -20 to 70°C

Humidity: 20 to 85%Ur non-condensing

WEIGHT

320g. in the complete version

FACEPLATE DESCRIPTION

A - PV display: indication of process variable

B - Label for engineering units

C - "Function" key

D - "Raise" and "Lower" keys

E - Indication of the states of the outputs

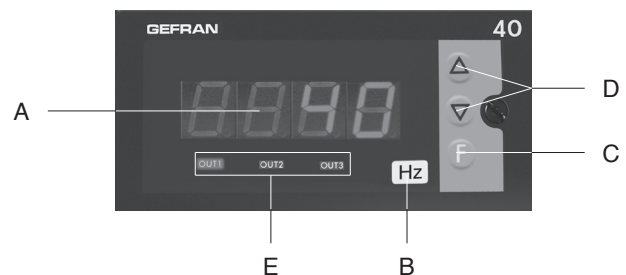

Red LED display

IP65 faceplate protection

DIMENSIONS and CUT-OUT

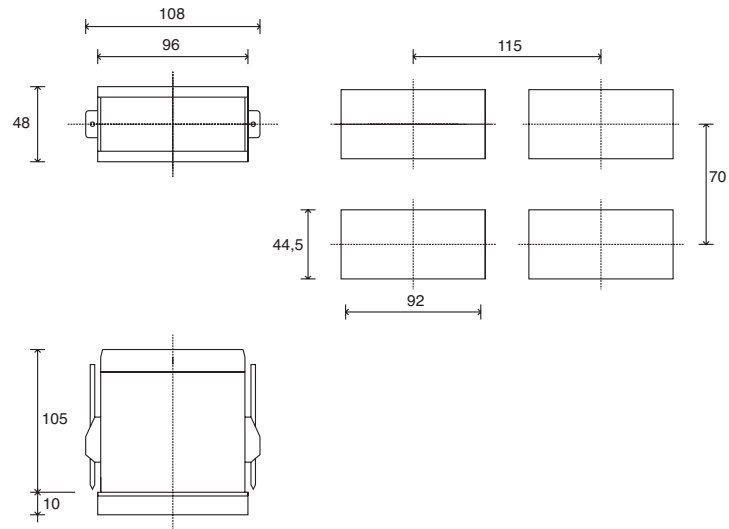

Dimensions: 96x48mm (1/8DIN), depth 105mm

CONNECTION DIAGRAM

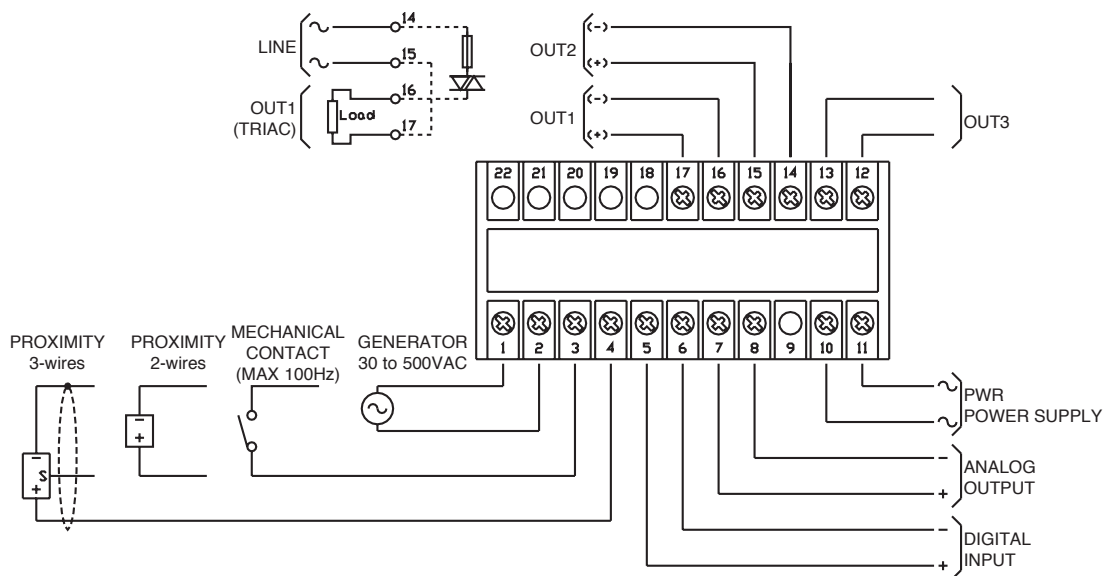

For a correct installation see the warnings in the users' manual

ORDER CODE

40F 96 4

NR. DIGITS	
4	4

TRANSMITTER POWER SUPPLY	
5Vdc	0 5
12Vdc	1 2
24Vdc	2 4

OUTPUT 1, OUTPUT 2	
Relay, Relay	R R
Relay, Logic	R D
Triac, None	T 0

POWER SUPPLY	
0	11...27Vac/dc
1	100...240Vac/dc

DIGITAL INPUT / RETRANSMISSION OUTPUT	
0	None
1	Digital input
3	Digital input + Analog output 4 to 20mA on max 150Ω

OUTPUT 3	
0	None
R	Relay

Please, contact GEFTRAN sales people for the codes availability.

GEFRAN spa reserves the right to make any modification of the design or function, at any moment without prior notice



EMC (electromagnetic compatibility): conforms to directive 2014/30/EU with reference to standard **EN61326-1**
 Safety LVD: conforms to directive 2014/35/EU with reference to standard **EN 61010-1**

GEFRAN